

PIPE / PIPE THREAD DIMENSIONS

Nominal Pipe sizes **do not match** any of its actual physical dimensions.

The OD of pipe / fitting must be measured & compared to the table for identification.

For example; a 3/4" NPT pipe thread has an outside diameter of 1.050 inches and 14 threads per inch. Each thread size has a defined number of threads per inch (TPI), but several sizes have the same TPI; because of this, both the TPI and OD of the thread are required for positive identification of thread size.

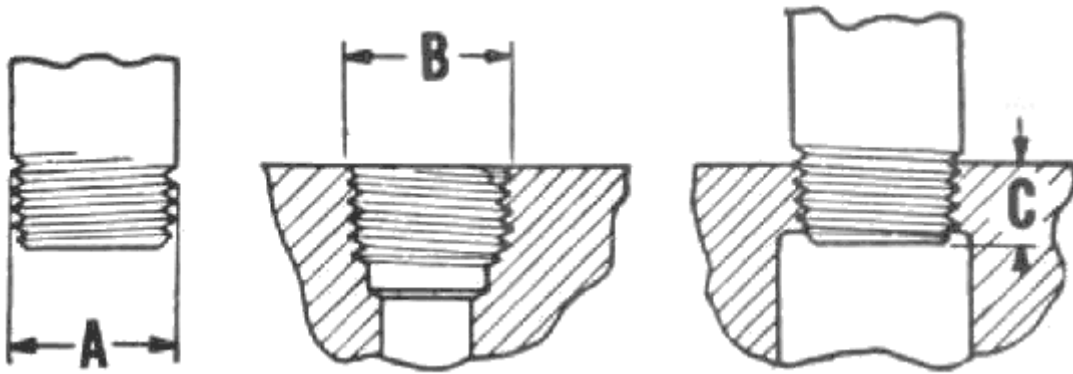

Male threads:

Measure the outside diameter of the large portion of the thread at "A"; Find figure nearest this dimension in column 1 or 2 of chart. The dimension in column 3 will be your nominal pipe thread size.

Female Threads:

Measure top diameter of thread at "B"; Find figure nearest this dimension in column 1 or 2 of chart. The dimension in column 3 will be your nominal pipe thread size.

Column 1	Column 2	Column 3	Column 4	Column 5
OD Fraction Inch (only for quick reference)	Actual Decimal Inch	Pipe Size Nominal	TPI Threads per Inch	Normal Engagement for a tight joint (dimension "C")
5/16"	0.3125"	1/16"	27	0.2611
13/32"	0.405"	1/8"	27	0.2639
35/64"	0.540"	1/4"	18	0.4018
43/64"	0.675"	3/8"	18	0.4078
27/32"	0.840"	1/2"	14	0.5337
1-3/64"	1.050"	3/4"	14	0.5457
1-5/16"	1.315"	1"	11-1/2	0.6828
1-21/32"	1.660"	1-1/4"	11-1/2	0.7068
1-29/32"	1.900"	1-1/2"	11-1/2	0.7235
2-3/8"	2.375"	2"	11-1/2	0.7565
2-7/8"	2.875"	2-1/2"	8	1.1375
3-1/2"	3.500"	3"	8	1.2000
4"	4.000"	3-1/2"	8	1.2500
4-1/2"	4.500"	4"	8	1.3000

Two common pipe thread sizes exist, the tapered **National Pipe Thread (NPT)** and the straight **National Standard Free-Fitting Straight Mechanical Pipe Thread (NPSM)**.

The tapered threads are for joining and sealing, the straight threads are only for joining.

Dry-seal thread (NPTF) allows for joining without sealants.

Female NPT threads may be designated as "FPT"

Male NPT threads may be designated as "MPT."

The pipe size is often written such as this 1/8"-27, with a hyphen between size & thread per inch, and pronounced as "one eighth twenty-seven"

Three less common threads exist, the **Garden Hose Thread (GHT)**, **Fire Hose Coupling (NST)** and **British Standard Taper Pipe Thread (BSPT)**.

The NPT and NPTF threads are interchangeable with sealants such as PTFE tape.

None of the other thread standards are interchangeable.

Definition Of Pipe Thread Acronyms

NPT National Pipe Thread

FPT Female (National) Pipe Thread

MPT Male (National) Pipe Thread

PTF SAE short tape pipe thread

NPTF American National taper pipe thread for Dryseal
pressure-tight joints

NPSM American National straight pipe thread for mechanical
joints

NPSI American National straight intermediate pipe thread
